



WS25G

L70
25°C

187,000 Hours

EasyLED Excel Square Bulkhead Grid Frame

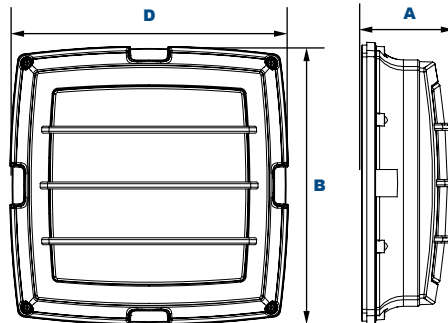

Dimensions

Width (D)	12½" (318mm)
Length (B)	12½" (318mm)
Height (A)	4¼" (108mm)

The Jemm Excel Square Bulkhead is designed to replace HID lighting systems up to 100w MH or HPS. The grid frame helps protect the polycarbonate lens and adds a decorative appearance. Typical applications include office and public buildings, condominiums, schools, shopping malls, and hospitality. Recommended mounting heights are 8 to 20 feet.

Specifications and Features:

Housing:

Die Cast Gasketed Aluminum Grid Front Frame and Housing with Integral Heat Sinking and Driver Compartment. Nickel-Plated Stainless Steel Hardware. Photocell Adaptable.

Listing & Ratings:

CSA: Listed for Wet Locations, ANSI/UL 1598, 8750; IP66 Sealed LED Compartment.

Finish:

Textured Architectural Bronze Powdercoat Finish Over a Chromate Conversion Coating. Custom Colors Available Upon Request.

Lens:

SoftLED LumaLens Polycarbonate Opal Vandal-Resistant Lens Eliminates LED Hot Spots

Mounting Options:

Surface Mount

EasyLED LED:

Aluminum Boards

Wattage:

Array: 17w, System: 19.7w; (100w HID Equivalent)

Driver:

Electronic Driver, 120-277V, 50/60Hz or 347V, 50/60Hz; Less Than 20% THD and PF>0.90. Standard Internal Surge Protection 2kV. 0-10V Dimming Standard for a Dimming Range of 100% to 10%; Dimming Source Current is 150 Microamps.

Controls:

Fixtures Ordered with Factory-Installed Photocell or Motion Sensor Controls are Internally Wired for Switching and/or 1-10V Dimming Within the Housing. Remote Direct Wired Interface of 1-10V Dimming is Not Implied and May Not Be Available, Please Consult Factory. Fixtures are Tested with LEPC Controls and May Not Function Properly With Controls Supplied By Others. Fixtures are NOT Designed for Use with Line Voltage Dimmers.

Warranty:

5-Year Warranty for -40°C to +50°C Environment.

See Page 2 for Projected Lumen Maintenance Table.

Order Information Example:

WS25GF17U5KLZSF

WS25G	F				L		
Model	Optics	Wattage	Driver	CCT	Lens	Color	Options
WS25G= EasyLED Excel Square Bulkhead Grid Frame	F=Type IV	1X17=17w	U=120-277V C=347V	4K=4000K 5K=5000K	L=SoftLED LumaLens Opal Polycarbonate Array Lens	Z=Bronze W=White C=Custom (Consult Factory)	SF=Single Fuse (120-277V Only) DF=Double Fuse (120-277V Only) SP=Surge Protector PC3=Photocell, 120-277VAC P10=Pencil Photocell, 120VAC P12=Pencil Photocell, 277VAC P14=Pencil Photocell, 120-277VAC S2=Microwave Sensor with Dimming for Mounting Heights of 8 to 40' (120-277V Only) BU=Battery Backup, 90 Minutes

Project Information:

Project Name: _____ Fixture Type: _____

Complete Catalog #: _____ Date: _____

Comments: _____

Certification & Listings:



Accessories & Replacement Parts:



P18103



P18110 & P18112



P18114



P17117

Replacement Parts (Order Separately, Field Installed)

P18103	120-277VAC Photocell
P18110	110-130V 120VAC Pencil Photocell
P18112	208-277V 240VAC Pencil Photocell
P18114	120-277V, 50/60Hz Pencil Photocell
P17117	Internal Microwave Sensor with Dimming for Mounting Heights of 8 to 40'. 120-277VAC, 50/60Hz.

For Replacement Battery Backup, see the LEPEG LED Battery Backup Specification Sheet.

Photometric Data

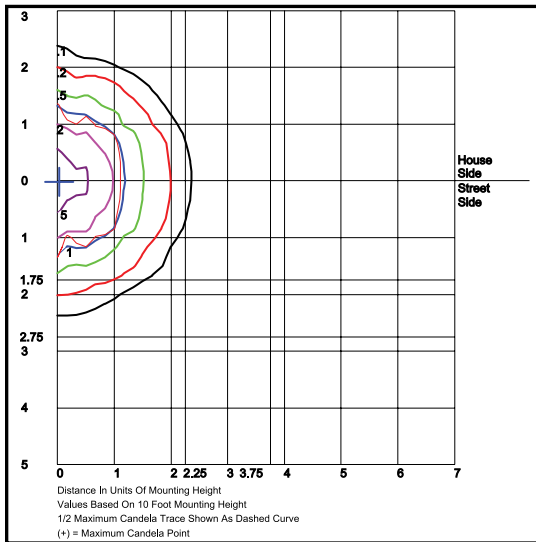

WS25GF17U5K
Type IV
Grid in MH
MH=10 Feet

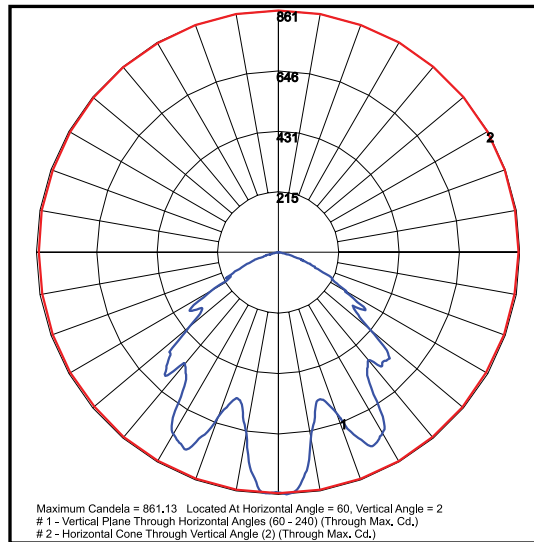

WS25GF17U5K
Type IV

Photometric Performance

LED Board Watts	Drive Current (mA)	Input Watts	Optics	5000 CCT 80 CRI				4000 CCT 80 CRI					
				Lumens	LPW	B	U	G	Lumens	LPW	B	U	G
EasyLED 17w	525	20	Type IV	1,923	96	0	4	2	1,846	92	0	4	2

Projected Lumen Maintenance

Data shown for 5000 CCT	Compare to MH						
	TM-21-11	Input Watts	Initial	25,000 Hrs	50,000 Hrs	100,000 Hrs	Calculated L70@ 25°C
L70 Lumen Maintenance @ 25°C / 77°F	20	1.00	0.96	0.92	0.84	187,000	
TM-21-11	Input Watts	Initial	25,000 Hrs	50,000 Hrs	100,000 Hrs	Calculated L70@ 50°C	
	L70 Lumen Maintenance @ 50°C / 122°F	20	1.00	0.96	0.91	0.82	113,000
TM-21-11	Input Watts	Initial	25,000 Hrs	50,000 Hrs	100,000 Hrs	Calculated L80@ 40°C	
	L80 Lumen Maintenance @ 40°C / 104°F	20	1.00	0.94	0.89	0.77	88,000

NOTES:

1. Projected per IESNA TM-21-11. Data references the extrapolated performance projections for the 525mA base model in a 25°C ambient, based on 10,000 hours of LED testing per IESNA LM-80-08.
2. Compare to MH box indicates suggested Light Loss Factor (LLF) to be used when comparing to Metal Halide (MH) systems.